

GRANITORY



CFB2

Granitor/Urządzenie do napojów lodowych typu twin o poj.2X11,3l



CFB3

Granitor/Urządzenie do napojów lodowych z 3 zbiornikami: 3X11,3l

Wybrane cechy produktu

Opatentowany, ergonomiczny kurek spustowy typu Push-Pull

Panele wykonane ze stali nierdzewnej, odporne na korozję

Zbiorniki o dużej pojemności 11,3l

Podświetlana zamykana pokrywa zbiornika

Tryb czuwania

Wbudowany Timer

Sygnalizator przepełnienia tacki ociekowej

Łatwy w czyszczeniu

GRANITOR

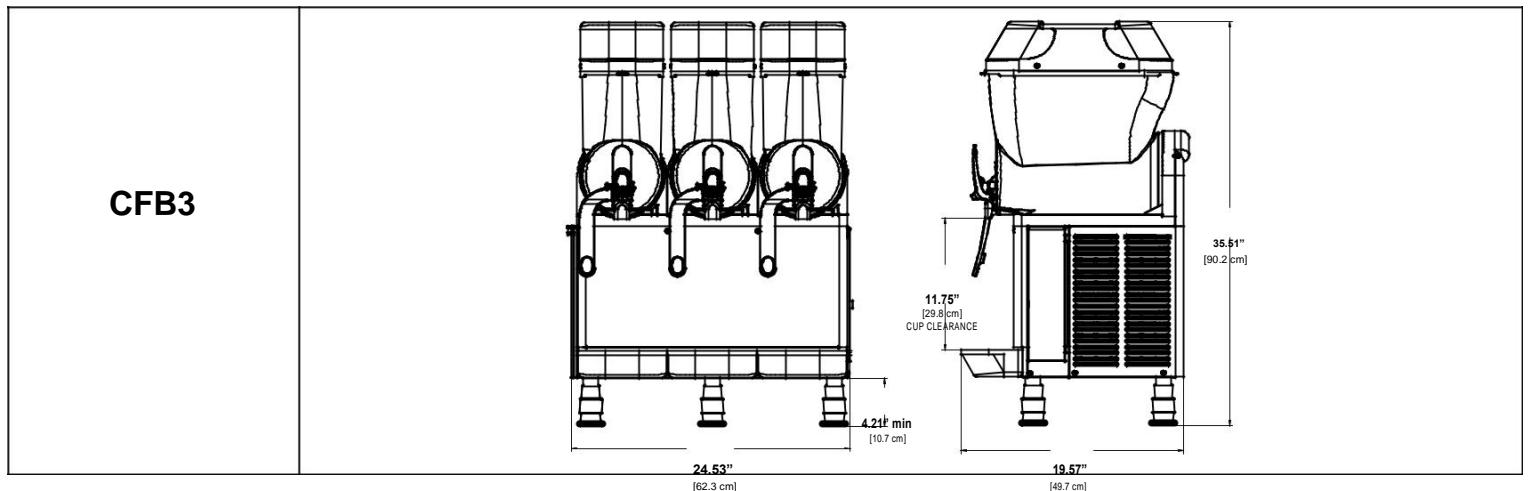
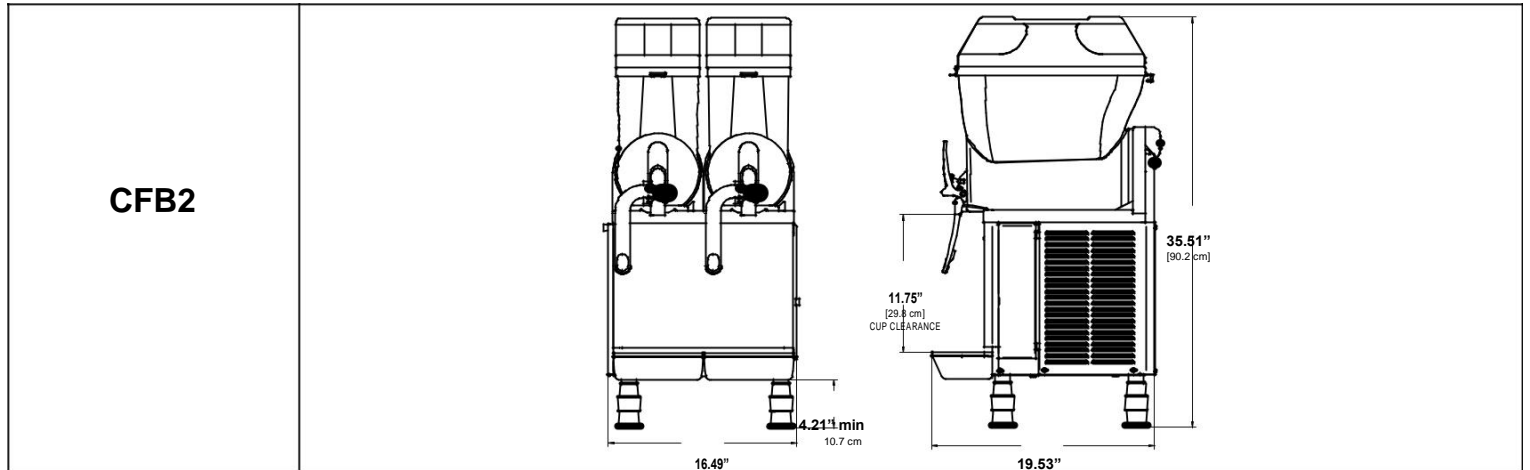

Specyfikacja

MODEL #	DESCRIPTION	CAPACITY	FAUCET CLEARANCE	HEIGHT x WIDTH x DEPTH	SHIP WEIGHT	SHIP CUBE
CFB2	Twin Frozen Beverage Machine	6.0 Gallons (2 x 3.0 Gal.)	11.75"	35.51" x 16.49" x 19.53"	132.0 lbs.	10.69 cu. ft.
CFB3	Triple Frozen Beverage Machine	9.0 Gallons (3 x 3.0 Gal.)	11.75"	35.51" x 24.53" x 19.57"	165.0 lbs.	14.20 cu. ft.

SPECIFICATIONS SUBJECT TO CHANGE WITHOUT NOTICE

Wymagania techniczne

MODEL #	PHASE	VOLTS	AMPS	ELECTRICAL MIN. CIRCUIT	WIRE	WATTS	HERTZ
CFB2	1 PH	115V	12.4A	15A	2W+G	1500W	50/60 Hz
CFB3	1 PH	115V	14.8A	20A	2W+G	1800W	50/60 Hz

SPECIFICATIONS SUBJECT TO CHANGE WITHOUT NOTICE



Wilbur Curtis Co., Inc. / 6913 Acco Street / Montebello CA 90640
 800.421.6150 / 323.837.2300 / www.wilburcurtis.com
 Perfecting the art of brewing since 1941

